

EnOcean Equipment Profiles

V 3.1

San Ramon, CA, USA
Original Release 3.0, 2019

Executive Summary

EnOcean Equipment Profiles (EEP's) are the fundament of interoperability between EnOcean devices of all different manufacturers. They define the coding of the data to be exchanged. EEP's are located at the application level of the EnOcean communication layers.

This document specifies the rules how EEP's shall be designed and used. It explains the different telegram types, coding and decoding of data to be transmitted, and their Teach-In data and processes. Ideally, the devices are interoperable when using the same EEP.

The various EEP's already defined are listed in the former xml EEP-Specification 2.6.8 which still is valid for the EEP descriptions. New profiles released, are available in the Alliance portal.

This document is owned by the Technical Working Group (TWG) of the EnOcean Alliance. It is maintained and will be progressed within the authority of the Chairman of the TWG.

Changes to this document have to be proposed to the EAC for review and to the TWG for decision.

REVISION HISTORY

Ver.	Editor	Change	Date
2.6.8	NM	Last xml edition of the EEP-Specification	Dec 31, 2017
3.0	AP	Copied all editorial content of the EEP-Specification 2.6.8 and rearranged the chapters. Incorporated TWG review comments	Jun 27, 2019 Aug 21, 2019 Sep 10, 2019
3.1	TR	Chapter "Timing of EnOcean Result Messages" added	Jun 5, 2020

Copyright © EnOcean Alliance Inc. (2025). All rights reserved.

DISCLAIMER

The information within this document is the property of the EnOcean Alliance and its use and disclosure are restricted. Elements of the EnOcean Alliance specifications may also be subject to third party intellectual property rights, including without limitation, patent, copyright or trademark rights (such a third party may or may not be a member of the EnOcean Alliance.)

The EnOcean Alliance is not responsible and shall not be held responsible in any manner for identifying or failing to identify any or all such third party intellectual property rights. This document and the information contained herein are provided on an "as is" basis and the EnOcean Alliance disclaims all warranties express or implied, including but not limited to

- (1) any warranty that the use of the information herein will not infringe any rights of third parties (including any intellectual property rights, patent, copyright or trademark rights, or
- (2) any implied warranties of merchantability, fitness for a particular purpose, title or non-infringement.

In no event will the EnOcean Alliance be liable for any loss of profits, loss of business, loss of use of data, interruption of business, or for any other direct, indirect, special or exemplary, incidental, punitive or consequential damages of any kind, in contract or in tort, in connection with this document or the information contained herein, even if advised of the possibility of such loss or damage. All Company, brand and product names may be trademarks that are the sole property of their respective owners.

The above notice and this paragraph must be included on all copies of this document that are made.

System Specification

The EnOcean Alliance “EnOcean Equipment Profiles Specification” and the “EnOcean Equipment Profiles definitions” are available free of charge to companies, individuals and institutions for all non-commercial purposes (including educational research, technical evaluation and development of non-commercial tools or documentation.)

This specification includes intellectual property („IPR“) of the EnOcean Alliance and joint intellectual properties („joint IPR“) with contributing member companies. No part of this specification may be used in development of a product or service for sale without being a participant or promoter member of the EnOcean Alliance and/or joint owner of the appropriate joint IPR.

These errata may not have been subjected to an Intellectual Property review, and as such, may contain undeclared Necessary Claims.

EnOcean Alliance Inc.
2603 Camino Ramon, Suite 200

San Ramon, CA 94583
USA
Graham Martin
Chairman & CEO EnOcean Alliance

Table of Content

- 1. Introduction.....6
 - 1.1. General6
 - 1.2. Viewing of profile data.....8
 - 1.3. Terms & Abbreviations.....9
 - 1.4. References10
- 2. EEP Approval Process..... 11
 - 2.1. Profile definition (duration: up to the submitter) 11
 - 2.2. Profile review (duration: approx. 4 weeks) 12
 - 2.3. Profile approval (duration: approx. 4 weeks) 12
 - 2.4. Official release 13
- 3. Telegram types..... 14
 - 3.1.1. RPS/1BS..... 14
 - 3.1.2. 4BS 15
 - 3.1.3. VLD..... 15
 - 3.1.4. MSC..... 15
 - 3.1.5. SMART Acknowledge 16
 - 3.2. Teach-In 17
 - 3.2.1. RPS Teach-In 18
 - 3.2.2. 1BS Teach-In 18
 - 3.2.3. 4BS Teach-In 19
 - 3.2.4. SMART Acknowledge Teach-in 21
 - 3.2.5. UTE – Universal Uni- and Bidirectional Teach-in 23
 - 3.3. Interoperability with High Security of EnOcean Networks 27
- 4. Timing of EnOcean Result Messages..... 29
 - 4.1. Use Case #1: Result Messages Triggered by Addressed Communication 29
 - 4.2. Use Case #2: Result Messages Triggered by Broadcast Communication 29
 - 4.3. Definition of Timing of EnOcean Result Messages 30
 - 4.3.1. Triggered by Addressed Messages 30
 - 4.3.2. Triggered by Broadcast Messages 30
- 5. EEP-Guideline 32
 - 5.1. Common requirements 32
 - 5.2. Recommendations 32

System Specification

- 5.3. Restrictions..... 33
- 5.4. Definition of enumerations..... 33
- 5.5. Usage of scales..... 34
- 5.6. Bi-directionality..... 35
 - 5.6.1. *Communication variants* 35
 - 5.6.2. *Directions*..... 36

1. Introduction

1.1. General

The EnOcean Radio Protocol (ERP) is optimized to transmit information with utmost reliability using extremely little power while ensuring that the products of customers applying EnOcean technology are compatible with each other. Only the very shortest transmission period (< 1ms) for an EnOcean telegram allows the design of, for example, a battery-free radio switch, which can produce a full radio command with just approx. 50 μ Ws (50 μ J) of energy. At the same time, the reliability of the system increases, as the possibility of data collision is strongly reduced.

Every data bit in the radio telegram is essential. For each '0' or '1' state, content descriptions are defined, which must be followed by the sender and the receiver likewise.

The ERP specification defines the structure of the entire radio telegram. The user data embedded in this structure is defined by the **EEP (EnOcean Equipment Profiles)**.

EEPs are one of the EnOcean Alliance's "languages" applied by devices communicating with each other. An EEP:

- describes the technical characteristics of a device,
- is optimized to transmit information with utmost reliability using extremely little power,
- defines the user data (payload) depending on the telegram type and the function of the device,
- is available to you as a machine-readable xml-file and a derived pdf-file

The objective of interoperability is easier to reach with as less profiles as required. Therefore, it is EnOcean Alliance's goal to configure each profile as universally as possible, to target a spectrum of devices in the building automation sector for all manufacturers.

It is of high interest to the EnOcean Alliance that Alliance members verify new devices or newly joined companies verify their products against the existing EEP's and adopt these during testing. Every newly defined EEP would increase diversity and therefore decrease interoperability.

The technical characteristics of a device define three profile elements, which make up the organizational description of all profiles:

1. The ERP radio telegram type (RORG)
2. Basic functionality of the data content (FUNC)
3. Type of device in its individual characteristics (TYPE)

System Specification

Therefore, every EEP has a number, reflecting these three components:

EEP 2.0:	ORG	FUNC	TYPE
EEP 2.5:	RORG	FUNC	TYPE
Range (hex):	00 ... FF	00 ... 3F	00 ... 7F
	8 bit	6 bit	7 bit

Every field is represented by a hexadecimal number, where the maximum value is limited by the available bits.

From EEP 3.0 we define all fields with 8 bits. This has impact for 4BS Teach-In, if FUNC > 3F, or TYPE > 7F, and in Remote Management, but will be explained there.

EEP 3.0:	RORG	FUNC	TYPE
Range (hex):	00 ... FF	00 ... FF	00 ... FF
	8 bit	8 bit	8 bit



System Specification

1.2. Viewing of profile data

The following example illustrates the HTML-view of the XML-data of a 4BS telegram (= payload of 32 bits).

Offset = start bit of data field
Size = bit number of data field
Bitrange = mapping to EEP2.0 description (specially for 4BS)
Data = content name
ShortCut = logical queries and dependencies in XML
Description of data field
Valid Range of data value
Scale of device value
Unit of scale value

Offset	Size	Bitrange	Data	ShortCut	Description	Valid Range	Scale	Unit
0	8	DB3.7...DB3.0	Not Used (= 0)					
8	8	DB2.7...DB2.0	Humidity	HUM	Rel. Humidity (linear)	0...250	0...100	%
16	8	DB1.7...DB1.0	Temperature	TMP	Temperature (linear)	0...250	0...40	°C
24	4	DB0.7...DB0.4	Not Used (= 0)					
28	1	DB0.3	LRN Bit	LRNB	LRN Bit	Enum:		
						0: Teach-in telegram		
						1: Data telegram		
29	1	DB0.2	Not Used (= 0)					
30	1	DB0.1	T-Sensor	TSN	Availability of the Temperature Sensor	Enum:		
						0: not available		
						1: available		
31	1	DB0.0	Not Used (= 0)					

Data ranges unused are displayed in the table as white rows.

The 'Bitrange' column displays the starting-point and the end-point of the respective data. As this is redundant to 'Offset' and 'Size', the column 'Bitrange' is no longer available in newer profiles.

The 'Valid range', 'Scale' and 'Unit' columns are displayed separately only for measurement values. However, these three columns are merged into one if the data comes from an enumeration (enum).

Assuming a linear conversion between the value to be measured and the 'valid range' of data the resolution can be calculated as follows:

Conversion: Valid Range ---> Scale

$$\text{Multiplier} = \frac{\text{Scale}_{\text{MAX}} - \text{Scale}_{\text{MIN}}}{\text{Range}_{\text{MAX}} - \text{Range}_{\text{MIN}}}$$

$$\text{Device value} = \text{Multiplier} * (\text{rawValue} - \text{Range}_{\text{MIN}}) + \text{Scale}_{\text{MIN}}$$

1.3. Terms & Abbreviations

1BS – EnOcean 1 Byte Communication

4BS – EnOcean 4 Byte Communication

Choice – Unique identification of EnOcean radio telegram types (RPS, 1BS, 4BS ...); equivalent with RORG

Client – Bidirectional SMART ACK Device

Data – Payload of ERP telegrams or ESP packets

EAC – EnOcean Equipment Profiles Approval Committee

EEP – EnOcean Equipment Profiles

ERP – EnOcean Radio Protocol

ESP – EnOcean Serial Protocol

EURID – EnOcean Unique Radio Identifier, a unique and non-changeable identification number assigned every EnOcean transmitter during its production process.

HTML – Hyper Text Markup Language; HTML can be displayed using a internet browser

MMI – Man Machine Interface

MSC – Manufacturer Specific Communication

ORG – Organizational number for EnOcean radio telegram types (out-dated with EEP 2.1; used for ESP2 interface)

RECOM – Remote Commissioning

REMAN – Remote Management

RMCC – Remote Management Control Commands

RORG – Radio ORG = organization number for EnOcean radio telegram types (new with EEP 2.1); equivalent with 'Choice'

RPC – Remote Procedure Calls, used in Remote Management

RPS – EnOcean telegram type for Repeated Switch Communication

SMART ACK – SMART Acknowledge EnOcean standard for energy-optimized bidirectional transmission

TWG – EnOcean Alliance Technical Working Group

VLD – EnOcean Variable Length Data telegram

XML – Extensible Markup Language; designed to transport and store data

XSL – Extensible Stylesheet Language; XML based language to visualize XML (data)

1.4. References

[1] EnOcean Equipment Profiles 2.6.8, EnOcean Alliance
<https://www.enocean-alliance.org/eep/>

[2] Smart Acknowledge specification, EnOcean Alliance
<https://www.enocean-alliance.org/smartack/>

[3] Security of EnOcean Networks specification, EnOcean Alliance
<https://www.enocean-alliance.org/sec/>

[4] Remote Management, EnOcean Alliance
[https:// www.enocean-alliance.org/reman/](https://www.enocean-alliance.org/reman/)

2. EEP Approval Process

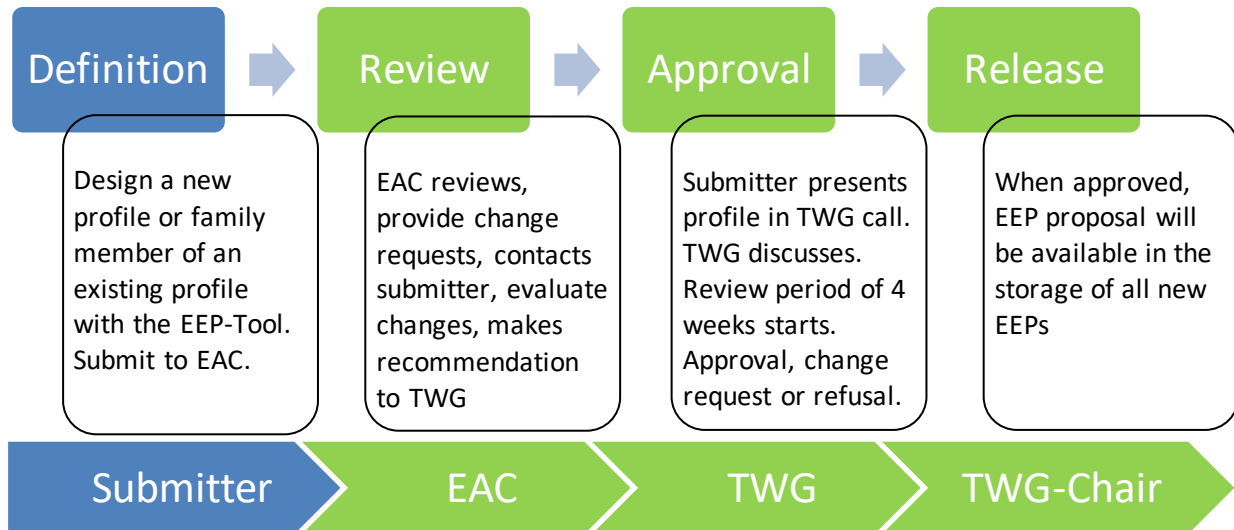

The normal processing time for an approval process is, at best, about 8 weeks. For this reason, it is recommended to specify a new EEP as early as possible and send it to the EAC team. The EAC team then has sufficient time to verify the new profile and can optionally support the submitter if changes need to be done to get the profile to the TWG for the review phase.

The argument that the product is "ready to ship" will not shorten the review and approval phase. For this reason, the EEP should be submitted at least 10 weeks before the start of production.

During holiday seasons (N. Hemisphere Summer, end of year season) there may be a delay in profile approval period.

2.1. Profile definition (duration: up to the submitter)

Specify your application in detail.

Before the definition of a new profile, existing profiles should be checked first for suitability. A new profile is to be defined only if the existing profiles would not be adequate. Check the latest EEP Specification as well as new EEPs in the pipeline issued for existing profiles that could be used for your application (If there is a suitable EEP, the process ends here).

Design a new profile or a new family member of an existing profile with the EEP-Tool according to your requirements following the EEP proposal guidelines. The EEP-Tool is a web-based application which helps companies designing and submitting a new EEP according to the requirements of a new or redesigned EnOcean device.

The EEP-Tool can be found here:

<http://tools.enocean-alliance.org/web/eepool0/index.php#>

As EEPs are the fundament of interoperability between EnOcean devices of all different manufacturers, profile definitions within the EEP Specification have to be clear and understandable.

The tool guides the user through the design of the EEP with the goal to reduce the workload for him and the approval process. Xml-data required for automated reading by gateways or development tools will be generated as well as a representation in a pdf file, the test containers and the IP representation.

Save your work in order to make any requested corrections later on!

Once a new profile is to be developed, it should be submitted to the EnOcean EEP Approval Committee (EAC) via e-mail (eep-proposal@enocean-alliance.org).

Kindly submit the generated .pdf, .xml and saved work files. Incomplete submissions will be rejected or significantly delayed!

2.2. Profile review (duration: approx. 4 weeks)

The EAC will review the profile proposal and:

- ...contact the submitter to discuss the proposal.
- ...provide change requests if necessary.
- ...evaluate made changes.
- ...make a recommendation for the profile presentation to the TWG.

After that, the EAC will forward the profile proposal to the TWG-Chair.

2.3. Profile approval (duration: approx. 4 weeks)

The TWG will review and ratify the profile. Following the recommendation by the TWG the BoD will disapprove or approve the profile.

1. The submitter presents the profile during an official TWG conference call.
2. The EAC recommends the profile for approval (or rejection).
3. The TWG discusses the presented EEP proposal(s).
4. The official TWG review phase (4 weeks) commences.
5. Every TWG member is allowed to provide questions, remarks or objections during the review phase, which are then forwarded to the submitter for response.
6. The review phase ends with:
 - a. The approval (no objections, no change requests) => the profile can be applied officially.
 - b. A change request => the profile is returned to the submitter and must be re-submitted.
 - c. A refusal => the profile is not accepted and may NOT be applied officially.

2.4. Official release

An approved profile will be added to the 'specification/new EEPs since 2.6.8' folder on the EnOcean Alliance platform. The pdf and xml files are stored in the respective subfolders. In each subfolder the approved EEPs are sorted according to their profile number.

System Specification

3. Telegram types

The various Radio-Telegram types are grouped ORganizationally.

The following RORG's are used:

Telegram	RORG	Description
RPS	F6	Repeated Switch Communication
1BS	D5	1 Byte Communication
4BS	A5	4 Byte Communication
VLD	D2	Variable Length Data
MSC	D1	Manufacturer Specific Communication
ADT	A6	Addressing Destination Telegram
SM_LRN_REQ	C6	SMART ACK Learn Request
SM_LRN_ANS	C7	SMART ACK Learn Answer
SM_REC	A7	SMART ACK Reclaim
SYS_EX	C5	Remote Management
SEC	30	Secure telegram
SEC_ENCAPS	31	Secure telegram with RORG encapsulation
SEC_MAN	34	Maintenance Security message
SIGNAL	D0	Signal telegram
UTE	D4	Universal Teach In

Structure of the telegram types

3.1.1. RPS/1BS

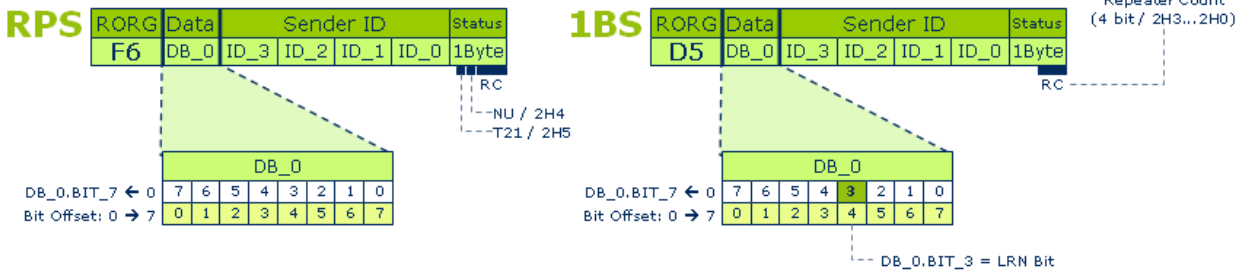

The RPS and the 1BS telegrams offer only 1-byte user data. These two telegrams differ in the respective learning operations (the 1BS has a LRN bit), and in the way the status byte is used.

Comment for RPS status bits:

T21 = 0 = PTM switch module of type 1 / synonymous for module PTM1xx T21 = 1 = PTM switch module of type 2 / synonymous for module PTM2xx NU = 1 = N-message (N = normal)

NU = 0 = U-message (U = unassigned)

System Specification

3.1.2. 4BS

A 4BS telegram carries a payload of 4 bytes. The sequence of the 4 data bytes is historically reversed, so that DB_3 appears first and DB_0 last on the radio interface. The bits are addressed in the sequence of the data flow, however (offset). Hence, DB_3.BIT_7 has the offset position 0 and DB_0.BIT_3 (LRN bit) has the offset position 28. The actual content-bits in a byte are not affected by this, i.e., they are described from right (2H0) to left (2H7) in the ascending order.

The example of a 10-bit temperature profile (see below) illustrates the binary valuation of the individual bits, so that a number range from 0 ... 1023 can be addressed.

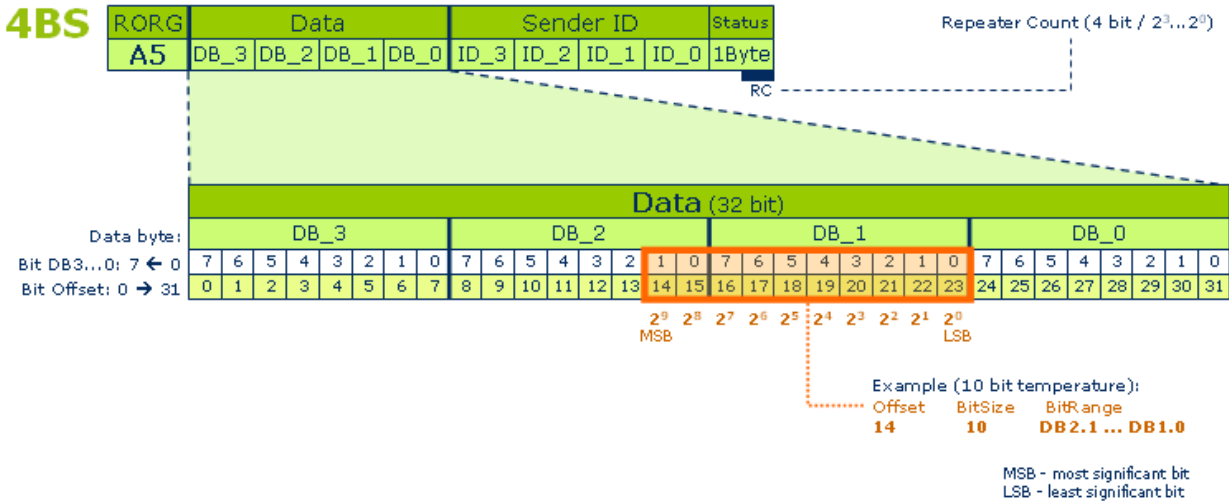

3.1.3. VLD

VLD (Variable Length Data) telegrams carry a variable payload between 1 and 14 bytes, depending on their design.

The following example displays a VLD telegram with 6 bytes user data. DB_5.BIT_7 is the first transmitted bit with offset 0.

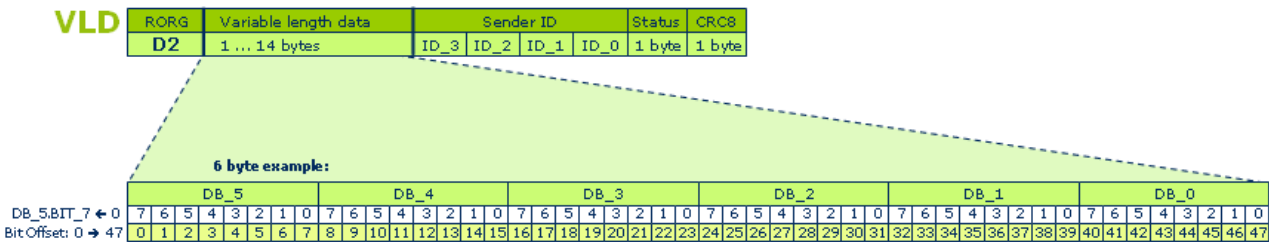

3.1.4. MSC

Communication over MSC (Manufacturer Specific Communication) telegrams can always be used when bigger data volumes are to be transmitted, and at the same time, a closed system



System Specification

structure is to be created. This can be the case if e.g., the controller system backbone is expanded to include radio components, or if safety-related controls require proprietary data structures.

Such communication must not affect any interoperable EEP-based communication and should be identifiable as MSC.

Interoperability Conditions:

A device using MSC in addition to other EEPs may be marked with the EnOcean ingredient logo, as long as it complies with the rules defined by the EnOcean Alliance for such markings. A device using MSC may be marked with the EnOcean ingredient logo even though the manufacturer does not disclose any or all information regarding the MSC payload. However, all other functionality of such a device shall comply with the latest EEP specification and such a device shall support at least one additional EEP. The manufacturer must clearly state which EEP(s) the device complies with. To safeguard interoperability, if there is sufficient justified doubt within the EnOcean Alliance TWG, a specific unit using MSC can be assessed by the TWG and if found to breach the interoperability intentions, the TWG may then decide (majority vote) to adapt the rules for the usage of the interoperability logo.

The MSC telegram has the same structure as a VLD telegram. The only difference is that the RORG Number is different and the payload specification is missing.

MSC

RORG	Manufacturer ID	Variable data	Sender ID				Status	CRC8
D1	1,5 byte	1 ... 12,5 bytes	ID_3	ID_2	ID_1	ID_0	1 byte	1 byte

The following points are to be noted:

1. The usage of the Multi User Manufacturer ID (0x7FF) shall not be allowed.
2. Each user may send MSC telegrams under his own Manufacturer ID. The Manufacturer ID should not be left out.

3.1.5. SMART Acknowledge

SMART ACK is a bidirectional communication protocol between a self-powered device and a line-powered controller. Data transmission in both directions is controlled by the sensor/client, as the limited energy budget requires an exact synchronization of the sent and the received messages. This pre-defined time interval allows a very short activation of the energy-intensive receiver electronics on the client.

Bidirectional VLD profiles may use SMART Acknowledge as the communication protocol. Please refer to the corresponding profile description.

Please refer to [2] for more details on SMART Acknowledge.

3.2. Teach-In

The 'Teach-in' defines the mutual communication between wireless devices in a radio network. The 'Teach-in' defines to which transmitter(s) a receiver needs to listen to.

For this purpose of a determined relationship between transmitter and receiver, each transmitting device has a unique Sender-ID (EURID), which is part of each radio telegram. The receiving device detects from the Sender-ID whether the device is known, i.e., was already learned, or unknown. A telegram with unknown Sender-ID is disregarded.

The teach-in method that a device uses depends on many factors, including whether or not the device uses security. If EEP's do not dictate whether a device uses security or not they must also not dictate the Teach-in method that a device shall use. The Teach-in section from former EEP documents can be ignored and for new EEP's will not be specified.

Also, some manufacturers may choose to use Teach-in methods that do not involve the EnOcean radio at all, i.e. NFC or QR-Code. But if the device supports Teach-in by EnOcean radio, the Teach-in process of this chapter has to be applied to ensure interoperability.

The 'Teach-in' process is different for each telegram type (RPS, 1BS, 4BS, SMART ACK), but the following points are valid for all telegrams:

- First, the receiver must be switched into learning mode. Now, the Sender-ID of an arriving telegram is interpreted as an authorized information source, and will be stored at the receiver. The further steps of 'teach-in' are defined by the device type or the telegram type. Thus, normal data telegrams or special teach-in telegrams can be used. Frequently, a learn button triggers the teach-in process.
- The telegram of the respective transmitter should be triggered at least once (by pressing the desired switch rocker or triggering a sensor).
- The bits of the payload (data bytes) can have multiple functions depending on the interpretation set by identification or status bits. Only in the 1BS and 4BS telegram the 'LRN BIT' DB_0.BIT_3 is reserved exclusively and must not be used elsewhere.

The following issues are relevant for a number of application but not mandatory for specification perspective:

- To prevent unwanted devices from being learned the input sensitivity of the receiver is often restricted, and thus an IN-ROOM operation is created. Typically, the device to be learned is placed close by the receiver.
- Transmitters can also be switched into the learn-mode via a remote management command. To avoid inadvertent learning the RPS telegrams have to be triggered 3 times within 2 seconds.

System Specification

3.2.1. RPS Teach-In

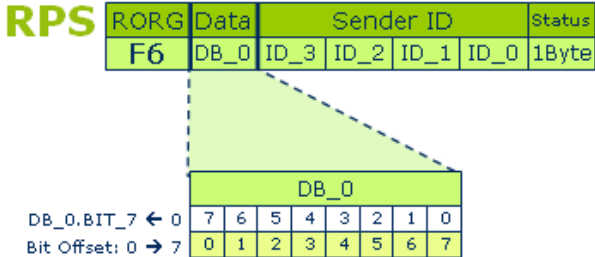

The RPS telegram can only send data and has no special telegram modification to teach-in the device. Therefore, the teach-in procedure takes place manually on the actuator/controller through a normal data telegram. The EEP profile must be manually supplied to the controller per sender ID.

In learn mode, the receiving actuator reduces the input sensitivity in order to fade out weakly received data telegrams. This helps avoid inadvertently teaching-in sensors.

3.2.2. 1BS Teach-In

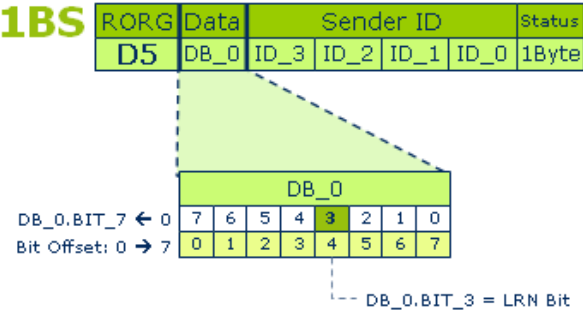

The 1BS telegram has its own teach-in telegram, which can signal the teach-in command through the DB_0.BIT_3 data bit.

Offset	Size	Bitrange	Data	Valid Range	Scale	Unit
4	1	DB0.3	LRN Bit	Enum :		
				0: Teach-in telegram		
				1: Data telegram		



System Specification

3.2.3. 4BS Teach-In

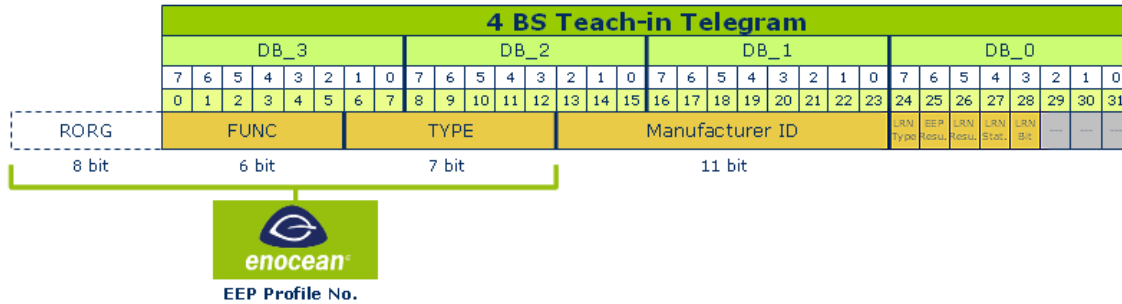

The 4BS telegram also has its own teach-in telegram, however with more teach-in variations:

Variation 1: Unidirectional profile-less

The profile-less unidirectional teach-in procedure works according to the same principle as the 1BS telegram: if the data bit DB_0.BIT_3 = 0, then a teach-in telegram is sent. This includes the 'LRN TYPE' DB_0.BIT_7 = 0 data bit. Then no EEP profile identifier and no manufacturer ID are transferred.

Offset	Size	Bitrange	Data	Valid Range	Scale	Unit
24	1	DB0.7	LRN Type	Enum : 0: telegram without EEP and Manufacturer ID		
28	1	DB0.3	LRN Bit	Enum : 0: Teach-in telegram 1: Data telegram		

Variation 2: Unidirectional with profile

For the unidirectional profile teach-in procedure, it is preferred in opposite to variation 1, as the teach-in telegram contains both the complete EEP number and the manufacturer ID. The device is therefore clearly identifiable as ready-to-use and can be securely executed in a complex system environment or by foreign systems. In this case, the 'LRN TYPE' data bit is DB_0.BIT_7 = 1. For FUNC > 3F or TYPE > 7F UTE has to be used instead of 4BS Teach-In.

Offset	Size	Bitrange	Data	Valid Range	Scale	Unit
24	1	DB0.7	LRN Type	Enum : 1: telegram with EEP number and Manufacturer ID		
28	1	DB0.3	LRN Bit	Enum : 0: Teach-in telegram 1: Data telegram		

System Specification

Variation 3: Bidirectional

During the bidirectional teach-in procedure, further bits are required from the DB_0, in order to develop the mutual teach-in between two communication partners. For this, the procedure is made up of 2 teach-in telegrams, which are exchanged on both sides. The following UML diagram is used to illustrate this:

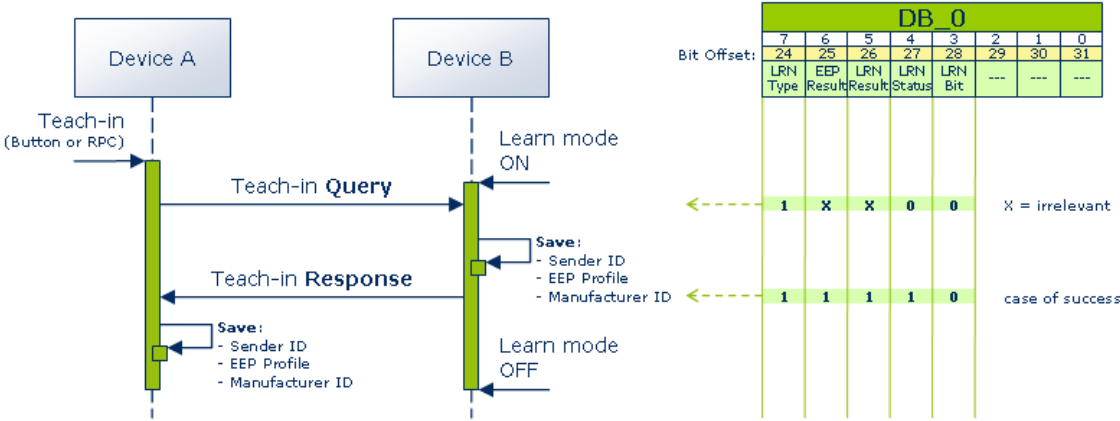

Offset	Size	Bitrange	Data	Valid Range	Scale	Unit
24	1	DB0.7	LRN Type	Enum : 0: telegram without EEP and Manufacturer ID 1: telegram with EEP number and Manufacture		
25	1	DB0.6	EEP	Enum : 0: EEP not supported 1: EEP supported		
26	1	DB0.5	LRN Result	Enum : 0: Sender ID deleted/not stored 1: Sender ID stored		
27	1	DB0.4	LRN Status	Enum : 0: Query 1: Response		
28	1	DB0.3	LRN Bit	Enum : 0: Teach-in telegram 1: Data telegram		

For FUNC > 3F or TYPE > 7F UTE has to be used instead of 4BS Teach-In

System Specification

3.2.4. SMART Acknowledge Teach-in

SMART Acknowledge is a bidirectional communication protocol between a self-powered device and a line-powered controller.

Under SMART Acknowledge (SA), the teach-in procedure is more complex as, alongside the SA client and SA controller, a Postmaster must also be established to prepare a mailbox for each taught-in SA client. The Postmaster is normally found in the controller.

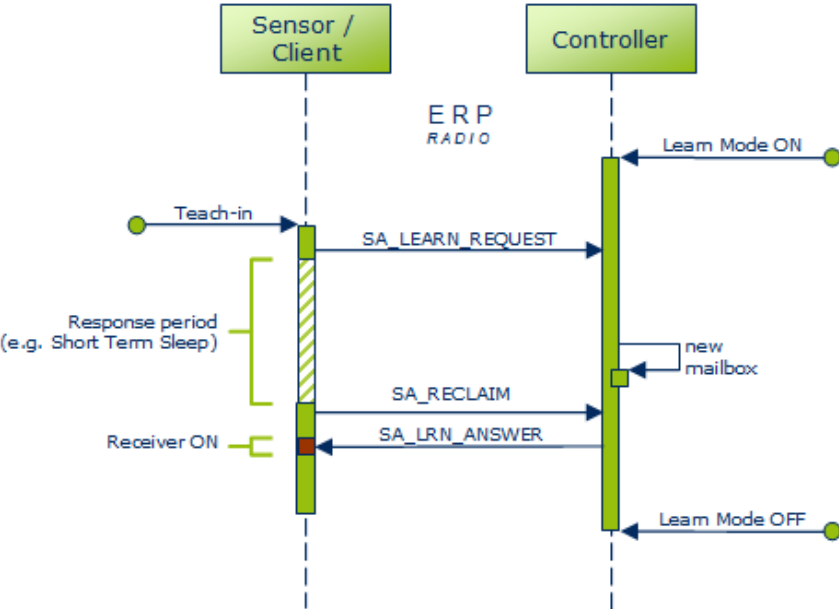

System Specification

If a repeater comes into operation, the **SA_LEARN_REQUEST** telegram sent by the SA client (with an EEP No., Manufacturer ID, Sender EURID) is completed on the repeater with the RSSI value (in dBm) and the Repeater EURID, and sent to the controller.

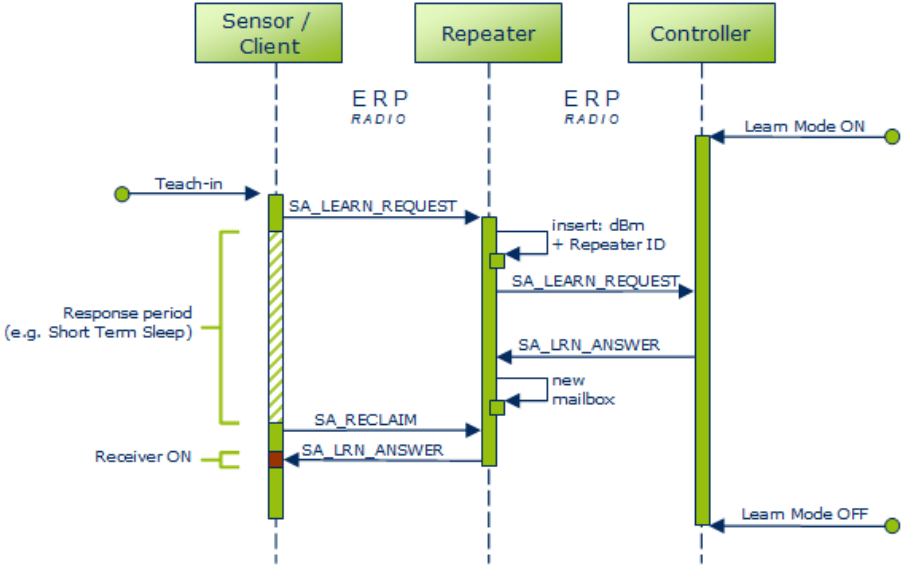

From the reception strength of the RSSI, the controller can recognize which repeater is best for the task of postmaster.

Please refer to [2] for more details on SMART Acknowledge.

3.2.5. UTE – Universal Uni- and Bidirectional Teach-in

General

There are different teach-in procedures available for:

- RPS communication (EnOcean ID + rocker/channel information, unidirectional)
- 1BS communication (LRN telegram, w/o EEP and MID, unidirectional)
- 4BS communication (LRN telegram, w FUNC+TYPE and MID, unidirectional)
- 4BS communication (LRN telegram, w FUNC+TYPE and MID, bidirectional)
- SMART ACK communication (self-powered devices, bidirectional)

For uni- and bidirectional EEP communication that does not fit into SMART ACK communication principles but is based on e.g. MSC and VLD messages no teach-in procedure is defined.

Therefore, this chapter describes the universal teach-in procedure that allows handling of teach-in and teach-out requirements for EEP based communication of all different RORG. UTE shall be understood as an alternative to SMART ACK teach-in for devices where SMART ACK is not applicable.

RORG to be used: **0xD4** Universal Teach-in, EEP based (UTE)

FUNC and TYPE are represented as 8-bit parameters, both with a value range from 0x00 ... 0xFF. This aligns UTE with the EEP representation defined for SMART ACK teach-in.

REMARK 1:

Even though the Universal Tech-In Procedure is able to cover EEPs based on RPS, 1BS and 4BS messages as well, it is not intended to replace the existing RPS, 1BS and 4BS teach-in / teach-out procedures for unidirectional and the existing 4BS teach-in / teach-out procedures for bidirectional communication.

However, it is recommended that with the acceptance of the Universal Tech-In Procedure all new bidirectional 4BS applications shall use it for teach-in and teach-out as well.

REMARK 2:

The Universal Tech-In Procedure is dedicated to EEP based EnOcean communication. It does neither compete with nor shall it interfere with the teach-in process of the Generic EnOcean Communication.

Communication – Principles and Definitions

BIDIRECTIONAL EEP-BASED COMMUNICATION

Bidirectional EnOcean communication means a point-to-point communication relationship between two enabled EnOcean devices. It requires all parties involved to know the unique EnOcean ID of their partners.

Such point-to-point communication relationship is established with the completion of a successful teach-in process and it is deleted with the completion of a successful teach-out process.

To get a maximum reliable teach-in process with a minimum consumption of energy and resources, a simple query-response mechanism is used: the device that is intended to be taught-in broadcasts a query message and gets back an addresses response message, containing its own EnOcean ID as the transmission target address.

In case there is more than one device ready to accept teach-in query messages at the same time and within the same radio range, the device with the quickest response time will be accepted by the device to be taught-in. Second and further devices will respond as well but they will not be accepted by the device to be taught-in. This will result in a configuration situation that is common to today's EEP based unidirectional teach-in processes.

UNIDIRECTIONAL EEP-BASED COMMUNICATION

Unidirectional EnOcean communication means a point-to-multipoint communication relationship between enabled EnOcean devices. In this case of broadcasting the device to be taught-in to other devices does not know the unique EnOcean ID of those communication partners.

The Universal Teach-In Procedure supports unidirectional EnOcean communication thru related configuration bits in the query message.

However, for specific applications – e.g. configuration feedback - it is also possible to combine a bidirectional teach-in process with a unidirectional EEP based communication during the regular operation of a device.



System Specification

EEP Teach-In Query - UTE Message (Broadcast / CMD: 0x0)

This message is sent by the EEP based EnOcean device that is intended to be taught-in to another device (which has been set into LRN-mode before either manually or thru a ReMan command).

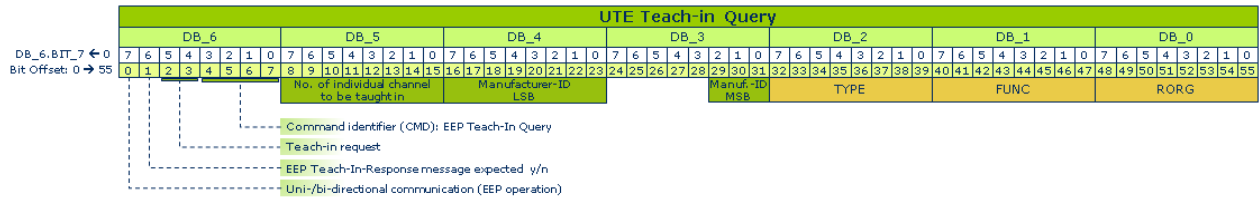

Offset	Size	Description	Valid Range	Scale	Unit
0	1	Communication during EEP operation	Enum: 0b0: Unidirectional 0b1: Bidirectional		
1	1	EEP Teach-In-Response message expectation	Enum: 0b0: Response expected 0b1: No Teach-In-Response		
2	2	Request type	Enum: 0b00: Teach-In request 0b01: Teach-In deletion request 0b10: Teach-In or deletion of Teach-in, not specified 0b11: Not used		
4	4	Command identifier (CMD)	Enum: 0x0: EEP Teach-In Query		
8	8	Number of individual channel to be taught in	0x00...0xFE Enum: 0xFF: Teach-In of all channels supported by the device	0x00...0xFE	Channel No.
16	8	Manufacturer-ID (8 LSB)	0x00...0xFF		
24	5	Not used (=0)			
29	3	Manufacturer-ID (3 MSB)	0x00...0x07		
32	8	TYPE	0x00...0xFF		
40	8	FUNC	0x00...0xFF		
48	8	RORG	0x00...0xFF		

Response Timing:

If a response is expected it shall be received within a maximum of 700ms from the time of transmission of this message. In case no such response is received within this period, the query action shall be treated as completed with negative result. If no response is expected, each query action has to be treated as completed with positive result.



System Specification

EEP Teach-In Response - UTE Message (Broadcast / CMD: 0x1)

This message is the reply to an EEP Teach-In Query message. It is sent by the EEP based EnOcean device that has been set into LRN-mode before (either manually by HMI or thru a ReMan command).

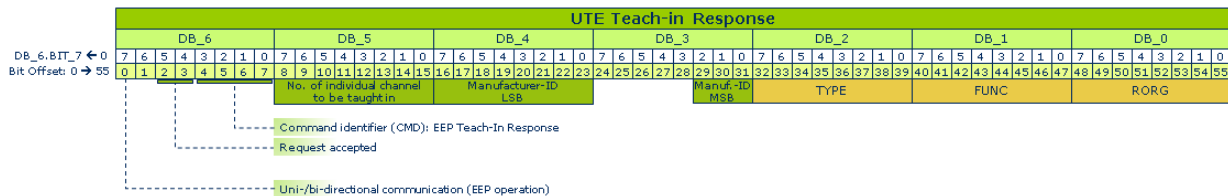

Offset	Size	Description	Valid Range	Scale	Unit
0	1	Communication during EEP operation	Enum:		
			0b0: Unidirectional		
			0b1: Bidirectional		
1	1	Not used (=0)			
2	2	Request type	Enum:		
			0b00: Request not accepted, general reason		
			0b01: Request accepted, Teach-in successful		
			0b10: Request accepted deletion of Teach-in successful		
			0b11: Request not accepted, EEP not supported		
4	4	Command identifier (CMD)	Enum:		
			0x1: EEP Teach-In Response		
8	8	Number of individual channel to be taught in	0x00...0xFE	0x00...0xFE	Channel No.
			Enum:		
			0xFF: Teach-In of all channels supported by the device		
16	8	Manufacturer-ID (8 LSB)	0x00...0xFF		
24	5	Not used (=0)			
29	3	Manufacturer-ID (3 MSB)	0x00...0x07		
32	8	TYPE	0x00...0xFF		
40	8	FUNC	0x00...0xFF		
48	8	RORG	0x00...0xFF		

Remark: DB5.7 to DB0.0 has same structure as Teach-in-Query and contents are echoed back.

Response Timing:

If a response is requested this message shall be sent within a maximum of 500ms from the time of reception of the EEP Teach-In Query message. This limit shall give sufficient time to decide on the teach-in request and answer accordingly (e.g., when requests need to be processed by data base systems connected asynchronously).

System Specification

3.3. Interoperability with High Security of EnOcean Networks

The Specification “Security of EnOcean Networks” [3] defines two new telegram types for high security EnOcean telegrams in operational mode:

- RORG = 0x30 = SEC Secure telegram
- RORG = 0x31 = SEC_ENCAPS Secure telegram with RORG encapsulation

To make sure that interoperability is warranted, both telegrams may be used for telegram transmission with existing EEP’s. Because the profile of the device is known, the data of the SEC or SEC_ENCAPS telegram contains the same information as described in the profile, but it may be encrypted defined by the SLF (Security level format) of the device. When the device uses more than one RORG’s in operational mode, the SEC_ENCAPS telegram has to be applied to ensure the correct original RORG after converting from high security to basic telegram.

Example for converting a telegram from basic to high secure and back:

Basic:	4BS	Data of profile	TX-ID	Status	Chk		
High Security:	SEC	Encrypted Data of profile	RLC	CMAC	TX-ID	Status	Chk
Basic:	SECD	Data of profile	TX-ID	Status	Chk		

The data of the known profile will be applied in the basic telegram after the conversion from high secure to basic telegram.

Example for converting a telegram from basic to high secure and back with encapsulated RORG:

Basic:	4BS	Data of profile	TX-ID	Status	Chk			
High Security:	SEC ENCAPS	4BS	Encrypted Data of profile	RLC	CMAC	TX-ID	Status	Chk
Basic:	4BS	Data of profile	TX-ID	Status	Chk			

After conversion from high secure to basic telegram, the encapsulated RORG will be applied in the telegram. The data of the profile of the encapsulated RORG will be applied.

Specifying the security level in the EEP would lead to the submission and creation of EEP’s that are identical to existing EEP’s except that they require a different security level. This would lead to less reuse of EEP’s.

All EEP’s therefore potentially support all security levels (including basic), and that no EEP’s require high security or a particular security level. The references to “Encryption supported”, “Encryption required”, or “Security Level Format” from existing EEP’s in former revisions of the EEP specification shall be ignored.

System Specification

High Security Teach-In procedure: (only if done by EnOcean radio)

1. Send secure Teach-In (SEC_TI) telegram(s) with basic security level to transmit SLF, secret key and RLC.
2. Send EEP-Teach-In with encapsulated R-ORG (SEC_ENCAPS) with high security (applying former transmitted SLF, key, RLC) to transmit the EEP profile number. Important is to transmit with encapsulated R-ORG, otherwise the receiver is not informed about the R-ORG.

4. Timing of EnOcean Result Messages

EnOcean Result Messages are sent by certain EnOcean devices either to communicate a status change that occurred during regular device operation or to answer a request message received from another device. EnOcean Result Messages are defined in several EEPs representing the communication of device status and measurement result data, but they are not limited to EEP based EnOcean communication.

EnOcean Installations may consist of a larger number of devices, e.g. actuators, which are all controlled by other devices that transmit addressed messages, e.g. gateways, or broadcast messages, e.g. rocker pushbutton switches.

If such controlled devices transmit Result Messages based on the reception of addressed or broadcasted messages, transmit timing needs to be thoroughly controlled to achieve best achievable communication performance and user experience.

EnOcean Messages related to SMART ACK, REMAN and RECOM communication are not covered by this chapter.

4.1. Use Case #1: Result Messages Triggered by Addressed Communication

In case one gateway controls several actuators through addressed messages, e.g. using EEP D2-01-00, response timing of each actuator should be as short as possible, thus, to allow for a feedback driven step-by-step execution of a switching scene related device list at maximum execution speed.

Maximum execution speed combined with correct status representation creates the best user experience, especially when working on a graphical man machine interface.

The same is true if a gateway or centralized controller needs to request status of each device taught-in after an MMI request, operational reset or power-up, using an EEP compliant number of individual addressed request messages.

4.2. Use Case #2: Result Messages Triggered by Broadcast Communication

In case one rocker pushbutton switch, defined as CENTRAL ON /OFF functionality, controls several actuators through broadcasted messages, e.g. using EEP F6-02-01, response timing of each actuator should be spread over time. This is, because status messages transmitted by the actuators in parallel will jam each other, plus they will block the radio channel for the original broadcast control message, especially if radio coverage is achieved using standard repeaters.

Optimized communication performance and user experience in this use case means, all actuators execute CENTRAL ON/OFF reliably on a first and single pushbutton press.

If a gateway controls the same actuators in parallel, the communication timing should make it possible for the gateway to derive correct status representation from the actuators status messages received.

The same is true if a gateway or centralized controller requests status of each device taught-in after an MMI request, operational reset or power-up, using an EEP compliant broadcast request message.

4.3. Definition of Timing of EnOcean Result Messages

For EnOcean Devices affected by this specification and introduced to the market first after January 1st, 2021, the following provisions shall apply.

In case definitions in EEPs contradict with provisions of this specification, this specification shall prevail.

4.3.1. Triggered by Addressed Messages

An EnOcean device receiving an addressed message that causes a reply, shall send such Result Message within 60ms from receipt of the addressed message.

If an EnOcean device can handle multiple messages triggering a reply in parallel, the following provisions shall apply:

In case a subsequent addressed message is received, which causes the same reply, prior to the Result Message of the before received message has been transmitted by the device, such first Result Message shall be cancelled and the addressed message received last shall be handled according to the definitions of this paragraph.

In case a subsequent broadcasted message is received, which causes the same reply, prior to the Result Message of the before received message has been transmitted by the device, such first Result Message shall be cancelled and the definitions of paragraph 4.3.2. shall apply.

4.3.2. Triggered by Broadcast Messages

An EnOcean device receiving a broadcasted message that causes a reply, shall send such Result Message within a time frame of 200ms ... 10,000ms from receipt of the broadcasted message. As an option, the Result Message may be repeated one or two times within the defined time frame. Transmit time(s) shall be spread randomly over this time frame and the data sent shall correspond with the to be sent data valid at the time of transmission.

If an EnOcean device can handle multiple messages triggering a reply in parallel, the following provisions shall apply:



System Specification

In case a subsequent broadcast message is received, which causes the same reply, prior to the Result Messages (1 ... 3) of the before received message have been transmitted by the device, such first Result Messages shall be cancelled and the time frame timer shall be retriggered with a random value.

In case a subsequent addressed message is received, which causes the same reply, prior to the Result Messages (1 ... 3) of the before received message have been transmitted by the device, such first Result Messages shall be cancelled and the definitions of paragraph 4.3.1. shall apply.

5. EEP-Guideline

This chapter shows what is to consider, when developing devices using EEP's or designing new EEP's.

5.1. Common requirements

Every submitted EEP is subject to change by the EAC, and may be turned down by the TWG. The unique profile number (i.e. the combination of R-ORG, FUNC, and TYPE) will be defined by the EAC. The EEP-tool's defaults are FF.

New profiles within the 1BS EEP family are not permitted and are not supported by the EEP-tool. RPS profiles are exclusively reserved for energy harvesting applications. If required, apply the old template to submit a RPS profile, please. 4BS profiles should not be created, as the user data is limited to 4 bytes. New profiles should therefore use VLD.

Configuration parameters for commissioning, or the application setup, have to be part of Remote Commissioning and not of the EEP data definitions.

For battery or energy level parameters, it is mandatory to use the Signal telegram. Such level parameters are not acceptable in new EEP proposals.

Every EEP constitutes an application. Profiles are not meant to combine different applications. Every application using a certain profile has to support all defined commands and parameters. Certain parameters within a profile can be optional as their values are not permanently available during runtime. Furthermore, it is possible to declare a parameter as 'not supported' if the application wants to show that the value is not only temporarily unavailable. Therefore, a parameter should include status information coded like this: 'valid' (value is valid), 'invalid' (value is temporarily invalid), 'not supported' (value is permanently invalid).

Profiles dealing with similar applications and data are bundled in EEP families (i.e. same FUNC). Within these EEP families, commands and parameters are used in the same way and new TYPES can be added by defining a new combination of parameters and/or adding new commands or parameters.

5.2. Recommendations

Sophisticated applications should use the Generic Profiles approach.

Profile titles, descriptions and parameters should use common terms (e.g. from existing profiles) to keep the profile documentations as simple as possible. Abstract parameter names (e.g. tint level) should be explained briefly.

The bits and bytes order should follow the data transmission order and alignment.



System Specification

5.3. Restrictions

The data content of new profiles should be unique. For this reason, new profiles may not include different scaling of data in different data bytes, where the valid scaling/data byte only is marked by a bit.

5.4. Definition of enumerations

An enumeration in an EEP parameter is an ordered listing of all the items in a collection. The set must be finite. The size of the enumeration is not limited. It is possible, that not all enumerations are used and so the unused ones are reserved.

Offset	Size	IP key	Description	Valid Range	Scale	Unit
...	3	Fanspeed	Fanspeed	Enum: 0: Auto 1: Speed 0 / OFF 2: Speed 1 3: Speed 2 4: Speed 3 5 ... 7: Reserved		

It is allowed that enumerations are defined in ranges of values.

Offset	Size	IP key	Description	Valid Range	Scale	Unit
...	8	PIR_state	PIR Status	Enum: 0...127: PIR off 128...255: PIR on		

The combination of enumerations with parameters having a valid range and scale are allowed. But they are required to have two different IP keys.

Offset	Size	IP key	Description	Valid Range	Scale	Unit
...	7	Position	Current vertical position	0...100	0...100	%
		Position_Unknown	Position unknown	Enum: 127: Position unknown		

Each enumeration IP-Key is unique over all EEPs. It is not allowed to use the same IP-Key name with different enumeration values and meanings.

It is allowed to extend reserved values of an existing enumeration. The size and the previous defined values remain unchanged and the reserved values will be occupied.

A device may use only a sub set of the defined enum values. In the following example, a device is allowed to use enum 2 and 3 if the device supports only two speeds of the fan.



System Specification

Offset	Size	IP key	Description	Valid Range	Scale	Unit
...	3	Fanspeed	Fanspeed	Enum: 0: Auto 1: Speed 0 / OFF 2: Speed 1 3: Speed 2 4: Speed 3 5: Speed 4 6 ... 7: Reserved		

5.5. Usage of scales

Scales define the minimum and maximum value of a measurement an EEP can transmit. In this example, the sensor measures the temperature from 0 to 50 °C and the humidity from 0 to 100 %.

Offset	Size	IP key	Description	Valid Range	Scale	Unit
0	8	Temperature	Temperature	0..250	Linear, 0...50	°C
		Status_	of Temperature Sensor	Enum:		
		Temperature		250..254: reserved		
				255: error		
8	8	Humidity	Relative Humidity (linear)	0...200	0...100	% RH
		Status_	Status of Humidity Sensor	201...254: reserved		
		Humidity		255: error		

If the used sensor HW is not able to measure the whole scale because of HW restrictions it is allowed to use a subset of the defined scale of the EEP. In this example it would be allowed to build a sensor which is only able to measure values from 5 °C to 40 °C or 10 to 95 %RH. The values the sensor cannot measure will never be transmitted.

It is not allowed to extend the scale limits of the EEP by using overflowed values.

System Specification

5.6. Bi-directionality

5.6.1. Communication variants

At present, 3 different communication variants having the existing XML structure can be mapped, which approximate the principles of a bi-directional data transfer. The teach-in procedure required for this is described in the same chapter.

The original terminology 'transmit mode / receive mode' was not taken over, as no unique assignment to device type and hence to transmission direction can be derived there from. A neutral number (Direction 1 / 2) or the state of a bit should allow the required free space to the individual application.

Variant 1:

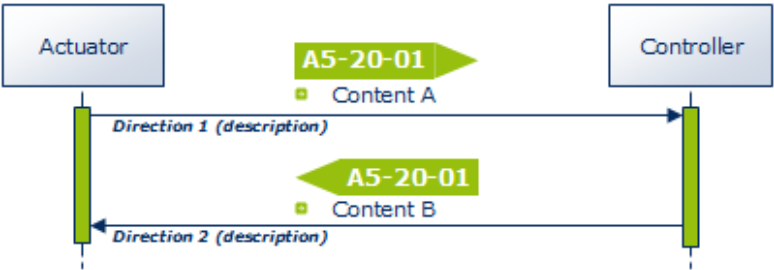

In Variant 1, there is no data-technical differentiation option in the 4BS telegram between Direction 1 and Direction 2, but only a documentation-related direction specification. No transmission direction can be detected if the telegrams are monitored on the radio stretch.

Variant 2:



System Specification

In Variant 2, three bits are provided in the 4BS telegram, which allow up to eight different data interpretations of the same EEP Profile No. through bit combination. One bit is used for direction (with the instruction text 'message source') and two bits for the Message ID.

Variant 3:

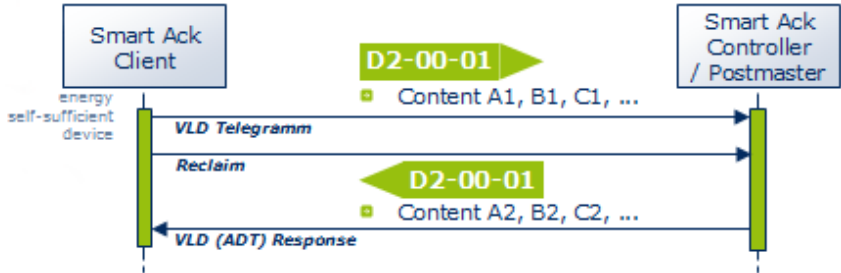

In Variant 3, the SMART ACK technology normally offers multiple use options of bidirectional data transmission. SMART ACK clients can therefore be energy self-sufficient devices. The used VLD telegrams allow a payload of up to 14 bytes (12.5 bytes with Manufacturer ID). Contents can thus be structured more individually.

5.6.2. Directions

For EEP commands, a direction has to be specified.

There are two valid directions: "FROM" and "TO". This is defined by the device that sent the teach-in request.

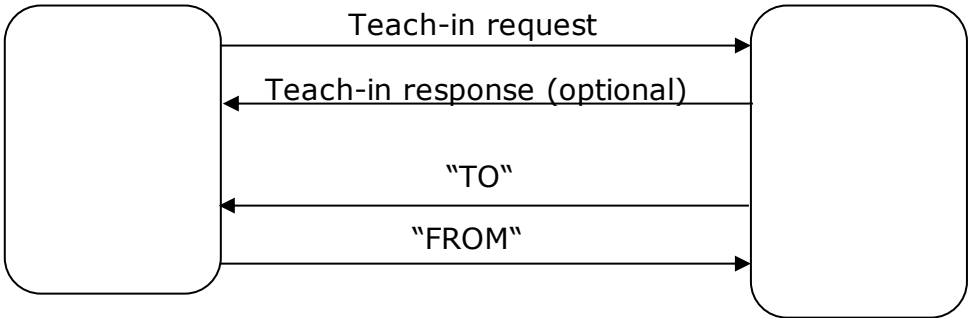

Device on the left is typically an actuator or a sensor. Device on the right is typically a gateway.

FROM: mainly used for 'response' or 'status' messages

TO: mainly used for 'set' or 'get/query' messages